

2.1 Area of a triangle

1 a Explain in words how to find the area of a triangle.

.....

b Write a formula connecting the area of a triangle (A), its base length (b) and its height (h).

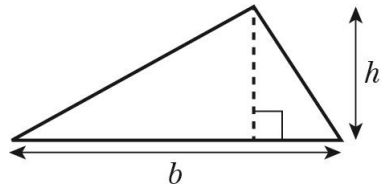

.....

2 Work out the area of each triangle.

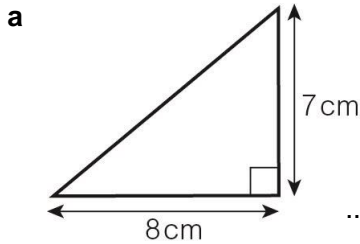

.....

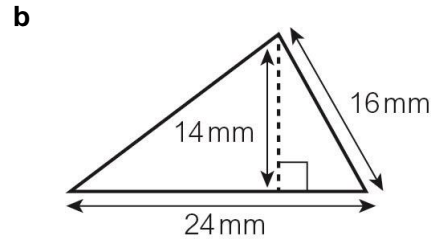

.....

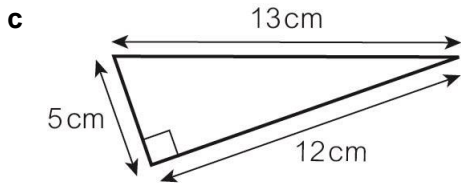

.....

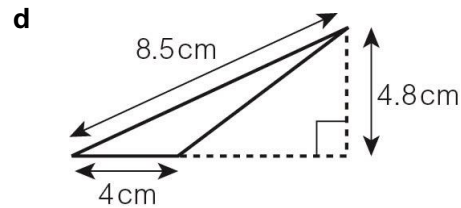

.....

3 **Problem-solving** This compound shape is made from two congruent triangles and a rectangle. What is the total area of the shape?



.....

4 **Problem-solving** This rectangular piece of card has a triangle cut from one corner. Calculate the area of the remaining card.

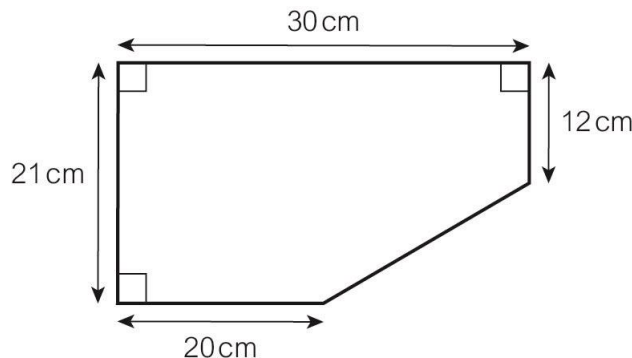

.....

2.1 Area of a triangle

- 1 **Problem-solving** Draw and label as many right-angled triangles with an area of 18 cm^2 as you can, using only whole numbers for the sides.

How will you know when you have drawn them all?

.....

- 2 A triangle has a base 4 cm and an area of 20 cm^2 .

a **Problem-solving** What is the perpendicular height?

b **Reasoning** Do you have enough information here to draw an accurate sketch of this triangle? Explain why.

.....

- 3 **Problem-solving** Work out the area of the shaded part of each shape.

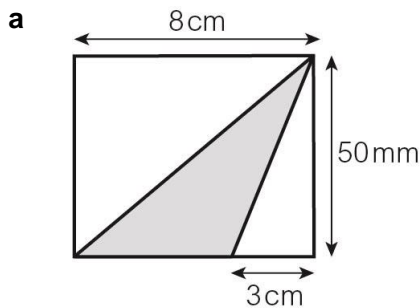

.....

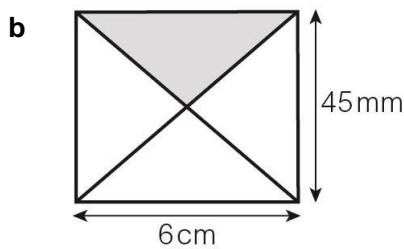

.....

2.1 Area of a triangle

1 Work out the area of each rectangle or square and of each shaded triangle.

a

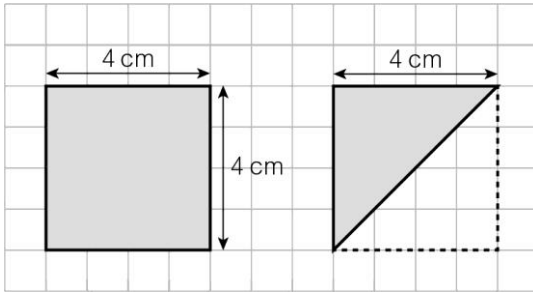

.....

b

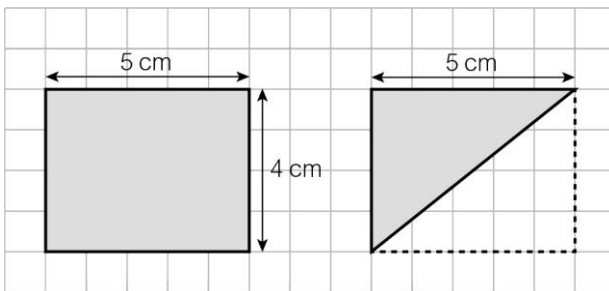

.....

c

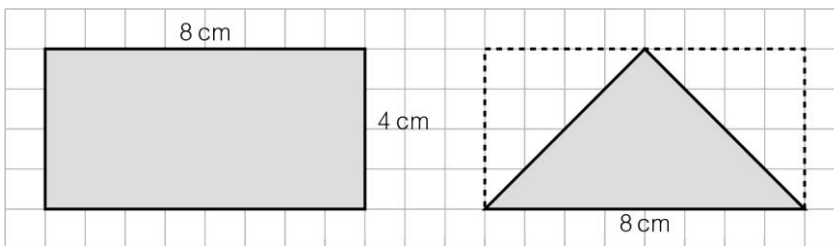

.....

2 Complete the drawing to make each triangle into a rectangle. Work out the area of each triangle.

a

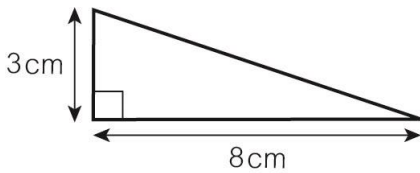

.....

b

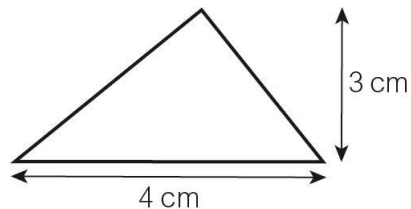

.....

c

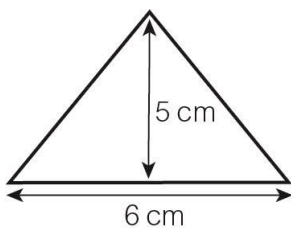

.....

3 Work out the area of each triangle.

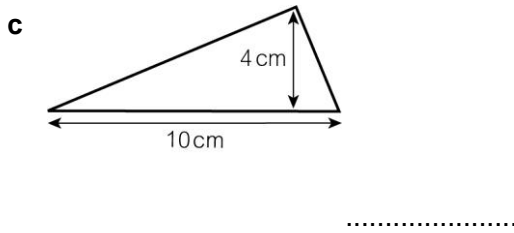
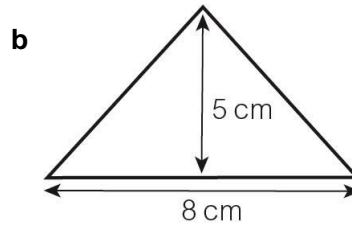
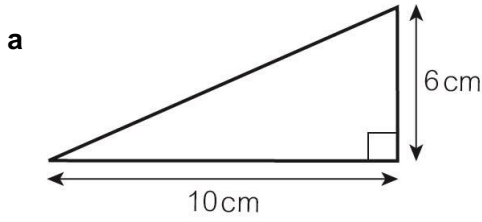

4 Work out the total area of each shape.

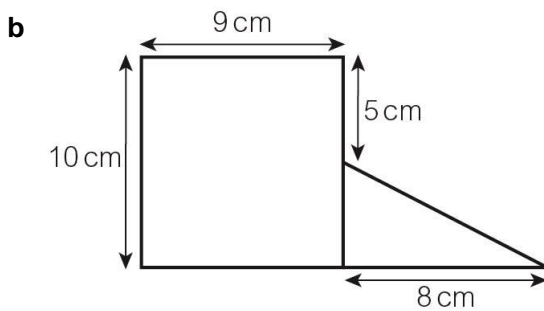
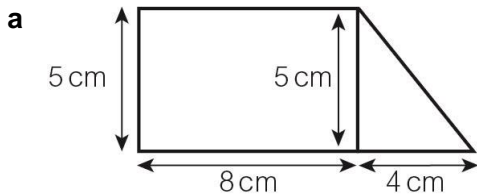

5 Work out the total area of each shape.

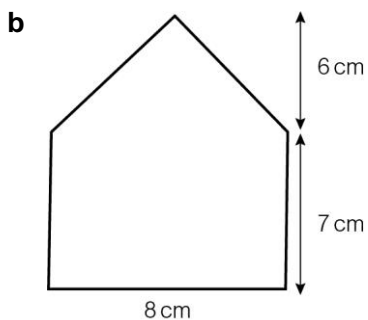
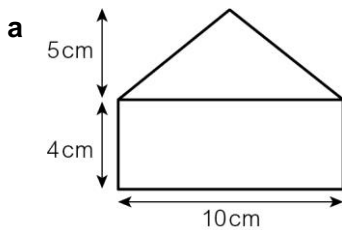

2.1 Area of a triangle

Core

- 1 **a** Half the base multiplied by the height **b** $A = \frac{1}{2}bh$
- 2 **a** 28 cm² **b** 168 mm² **c** 30 cm² **d** 9.6 cm²
- 3 152 cm²
- 4 585 cm²

Depth

- 1 Students draw and label 5 right-angled triangles: 36 cm by 1 cm, 18 cm by 2 cm, 12 cm by 3 cm, 9 cm by 4 cm and 6 cm by 6 cm. You know you have drawn them all when you have used all the factor pairs of 36 as side lengths.
- 2 **a** 10 cm
b No, as we do not know either of the other two lengths; there are multiple possible triangles that have that base and perpendicular height.
- 3 **a** 12.5 cm² **b** 6.75 cm²

Support

- 1 **a** 16 cm² and 8 cm² **b** 20 cm² and 10 cm² **c** 32 cm² and 16 cm²
- 2 **a** 12 cm² **b** 6 cm² **c** 15 cm²
- 3 **a** 30 cm² **b** 20 cm² **c** 20 cm²
- 4 **a** 50 cm² **b** 110 cm²
- 5 **a** 65 cm² **b** 80 cm²